

**HIGH PERFORMANCE MATERIALS**  
FOR CARD MANUFACTURING AND PERSONALISATION

# WELCOME TO CARDEL LTD

Core Materials & Overlays	2
Magstripe Overlays	5
Lamination Press Pads	7
Lamination Plates	10
Hi Bond Adhesives	14
Perso & Fulfilment	19

## ■ ■ ABOUT THE CARDEL GROUP

The Cardel Group is a leading manufacturer of high-quality products used for card manufacturing and distribution. We are a global player, with international manufacturing facilities. Our customers include private and public sector issuers of cards and documents, who demand the highest levels of flexibility, quality, security and efficient production.



## CORE MATERIALS & OVERLAYS

Cardel® offers a wide range of coated and un-coated PVC core and overlay options, meeting various application and printing system requirements. With vibrant finishes and exceptional strength, they provide the perfect foundation for producing high-quality financial cards, ID cards, and other general purpose cards.

# PVC CORE MATERIALS

Cardel® PVC core material is available in sheet format, in a range of thicknesses from 100 micron to 800 micron. Our standard PVC core material is white, however, it is also available in transparent and a wide range of colours. Composite cores of PVC/ABS and rPVC/ABS are also available.

Our core sheets are designed to enhance the durability, functionality and appearance of your laminated cards. Optimal bond strength is achieved by using a matching Cardel® PVC core and overlay. Cardel® can provide advice on core and overlay suitability based on your individual application and printing ink technology.

	Sector	Virgin/Recycled PVC	Vicat B (B50) °C	Product Code
Uncoated PVC Core	Banking	PVC	74 ± 2	PVC-ABU
		rPVC	74 ± 3	rPVC-ABU
Suitable or standard offset litho & waterless offset litho	Non-banking	PVC	78 ± 2	PVC-ANU
		rPVC	76 ± 3	rPVC-ANU
Coated PVC Core	Banking	PVC	70 ± 3	PVC-ABI
		rPVC	72 ± 4	rPVC-ABI
Suitable for HP Indigo	Non-banking	PVC	74 ± 3	PVC-ANI
		rPVC	74 ± 4	rPVC-ANI

**Material for MGI toner / Inkjet digital available on request.**

**Composite cores of PVC/ABS and rPVC/ABS are also available, along with PET and others.**

## RECYCLED PVC CORE

All our recycled PVC is produced using a 100% post-industrial PVC stream, ensuring a reliable and sustainable supply chain. To ensure optimal product processing and performance, some additives are added during production of the recycled PVC core. Our recycled PVC products are certified using the Environmental Claim Validation Procedure (ECVP) for recycled content (UL 2809 - Fifth Edition) as containing a minimum of 99% recycled content.



# PVC OVERLAY

Cardel® PVC overlay material is available in thicknesses from 50 micron to 120 micron and in sheets or on reels. Overlays can be provided with pre-laid magstripes in both reel and sheet format. Cardel® PVC and rPVC overlays are also available in an uncoated format.

Our overlays are designed to enhance the durability, functionality and appearance of your laminated cards. Optimal bond strength is achieved by using a matching Cardel® PVC core and overlay. Cardel® can provide advice on overlay and suitability based on your individual application and printing ink technology.

	Standard/Laserable	Virgin/Recycled PVC	Vicat B (B50) °C	Product Code
Litho Overlay Suitable for standard offset litho	Standard	PVC	67 ± 3	OL-AL
		rPVC	65 ± 3	rOL-AL
	Laserable	PVC	67 ± 3	OL-ALL
		rPVC	65 ± 3	rOL-ALL
Indigo Overlay Suitable for HP Indigo, Inkjet/digital & waterless offset litho	Standard	PVC	68 ± 3	OL-AI
		rPVC	65 ± 3	rOL-AI
	Laserable	PVC	68 ± 3	OL-AIL
		rPVC	65 ± 3	rOL-AIL

## RECYCLED PVC OVERLAY

All our recycled overlay is produced using a 100% post-industrial PVC stream, ensuring a reliable and sustainable supply chain. To ensure optimal product processing and performance, some additives are added during production of the recycled PVC overlay. Our recycled PVC products are certified using the Environmental Claim Validation Procedure (ECVP) for recycled content (UL 2809 - Fifth Edition) as containing a minimum of 99% recycled content.

# MAGSTRIPE OVERLAYS

Cardel® magstripe overlays are available in a variety of thicknesses, including 50, 60, 80, 100, and 120 microns. They are laid with standard magstripe widths of 8.4mm or 12.7mm and are offered in three coercivity options: 300 Oe, 2750 Oe, and 4000 Oe. Our overlays are available with a wide selection of standard and bespoke magstripe colours.

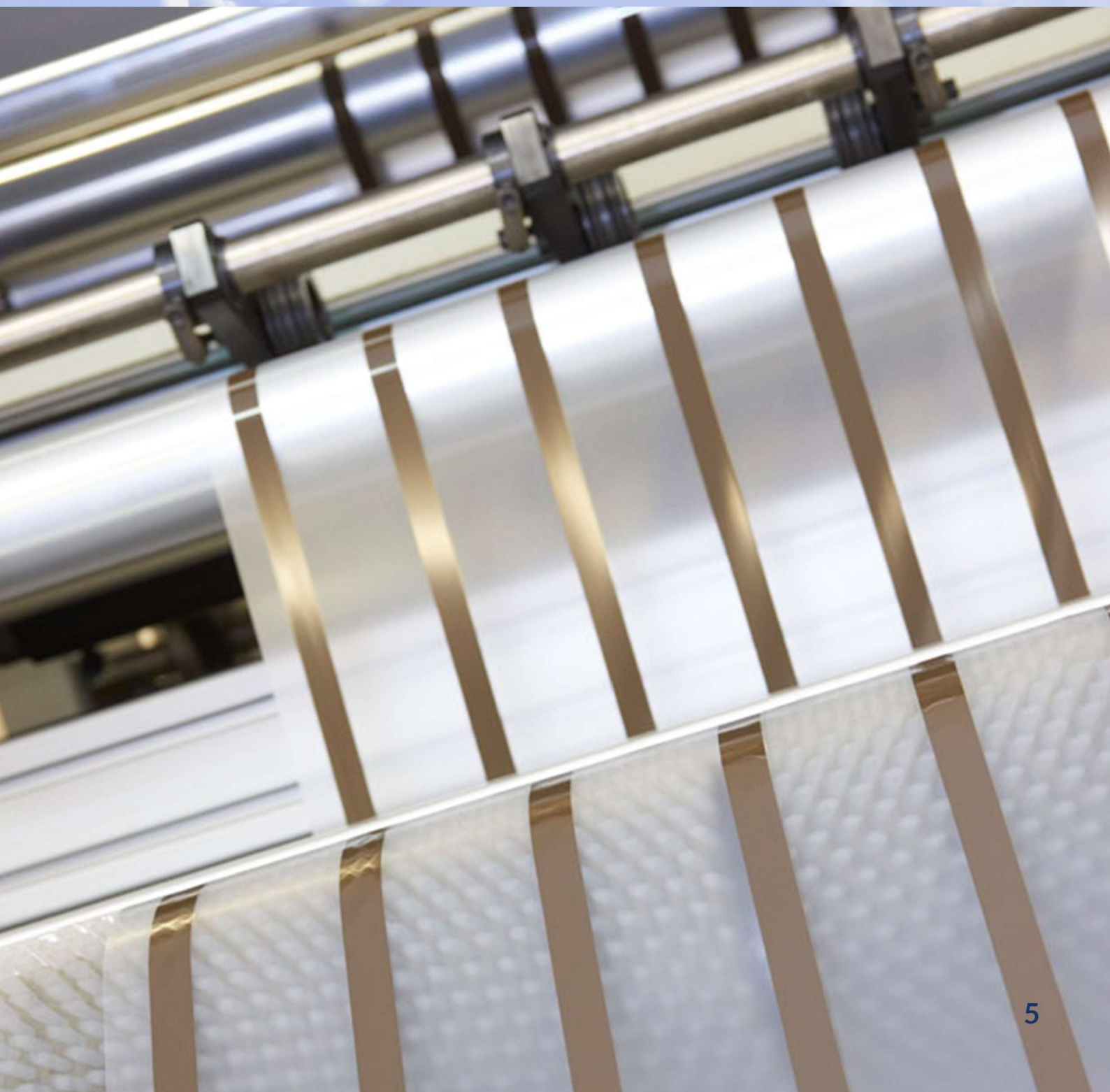

# PVC OVERLAY WITH MAGSTRIPE

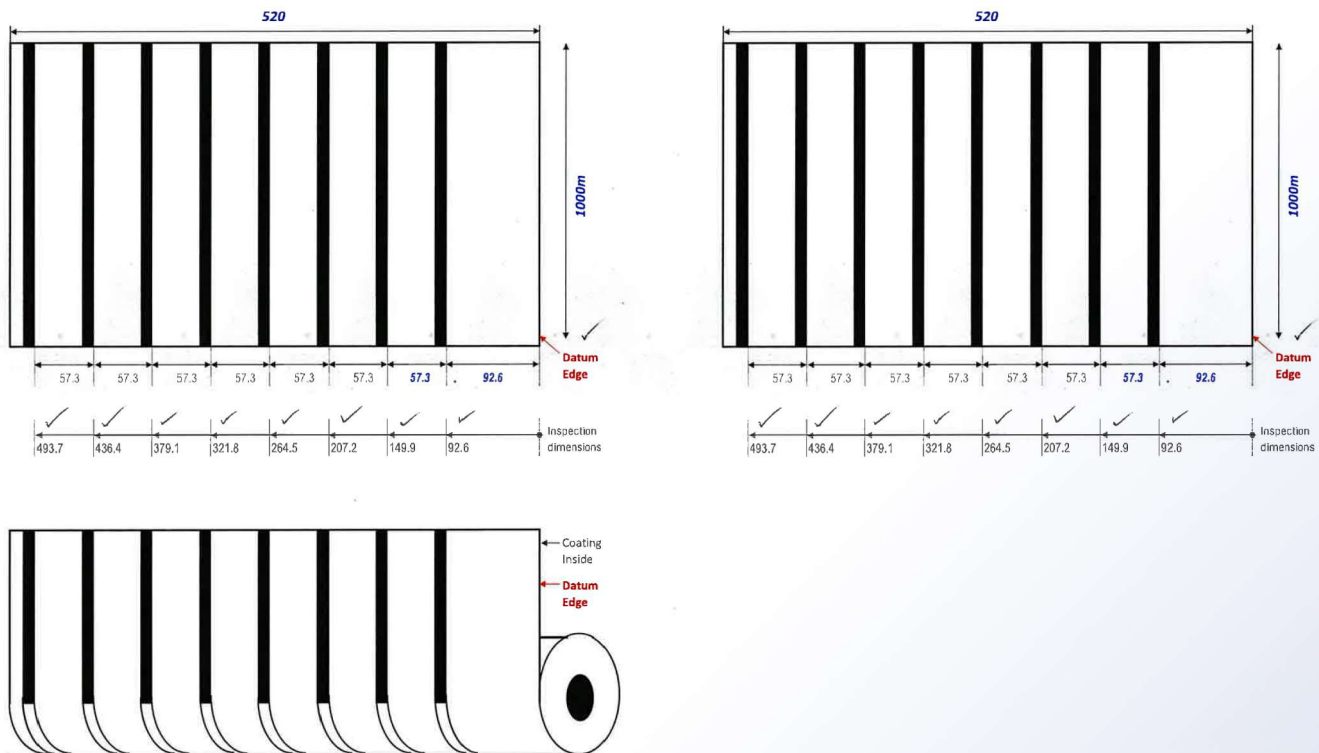

## Available in rolls or sheets

Our pre-laid magnetic stripes offer exceptional reliability and precision for card production. Designed for seamless integration, they ensure ease-of-use and accurate placement - making them ideal for financial cards.

Cardel® is one of the worlds largest producers of magnetic stripes pre-laid on PVC overlay. Our technical team has years of experience working with our customers to provide the best Cardel product for their specific print and lamination environments - ensuring high quality, high yield and ISO compliance every time.

We work with our customers to understand their production environment and applications to ensure that we offer the highest performance overlay and magnetic stripe materials appropriate to them. This ensures our customers products comply with all international standards at competitive prices.

## MAGSTRIPE

Our magnetic stripes come in Lo-Co (3000e) and Hi-Co (27500e & 40000e) and in 8.4mm and 12.7mm widths as standard. We offer customisation options including a wide range of standard colours, bespoke Pantone colours, plus text, logo and design printing.

The standard length of each roll is 2000m and it is available for both plastic and board cards.



# LAMINATION PRESS PADS

Built for durability and precision, Cardel Cardlam® lamination press pads are expertly crafted to deliver even heat and pressure distribution throughout the lamination process. They guarantee consistent performance and superior finishes, making them a dependable option for financial cards, IDs and various other card applications.

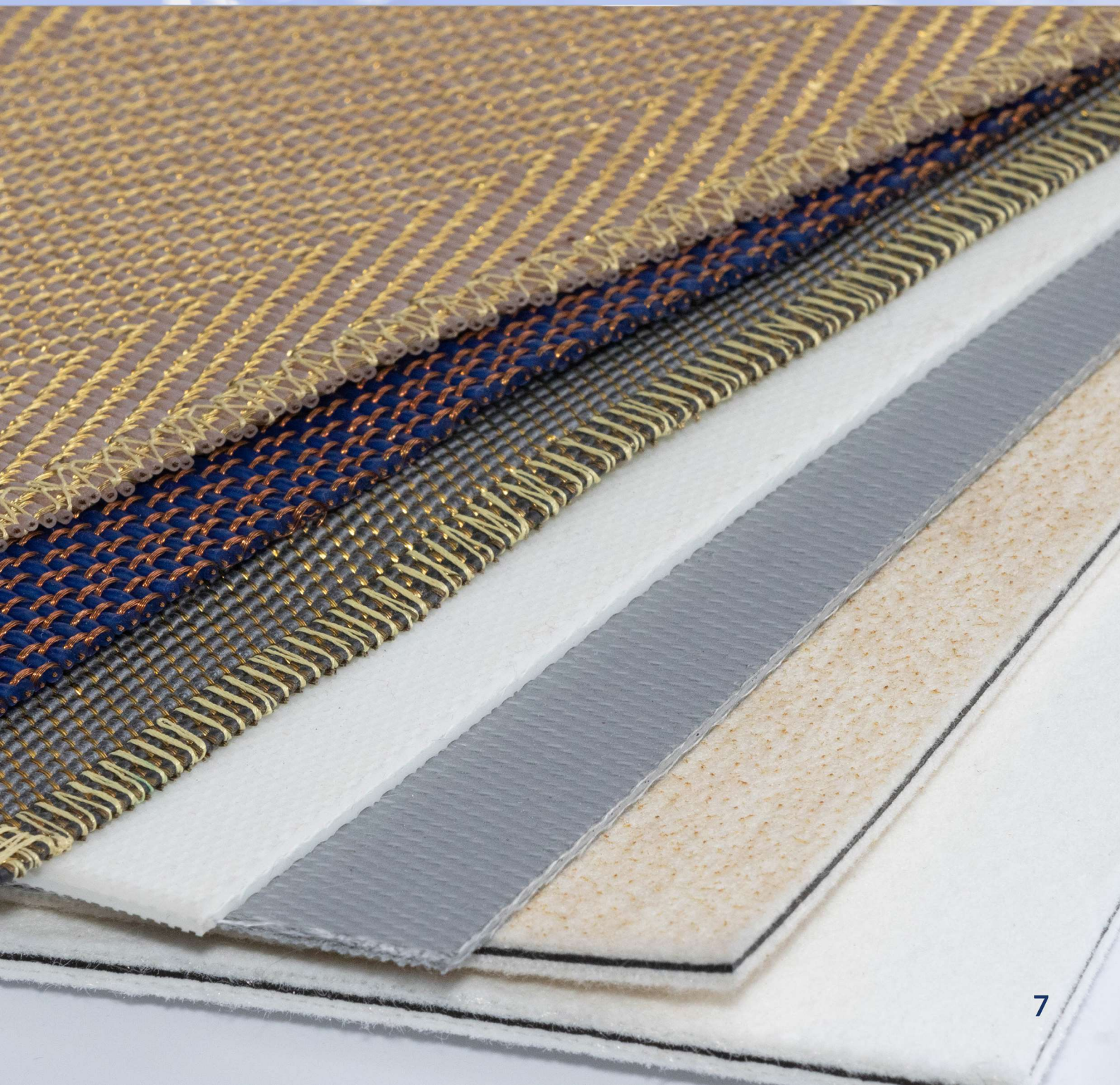

# LAMINATION PRESS PADS

Cardel Cardlam® lamination pads are designed to provide optimal heat and pressure distribution during card production. Engineered for durability and precision, they ensure consistent results and high-quality finishes, making them a reliable choice for financial cards, ID's and other card applications.

The Cardel® team work closely with customers to ensure we understand their operating environment and any specific requirements, so we can offer the most appropriate pad construction. Cardel Cardlam® pads are available in a range of materials and composite layered formats, using aramid, butyl rubber, silicone, brass and copper.

**C200** Lamination pad with smooth heat transfer and additional cushioning. Suitable for all types of medium / high volume single and twin stack laminators. The construction consists of an aramid fibre outer and a high-density heat-resistant rubber inner.



**C220** High efficiency lamination pad with fast heat transfer. Suitable for all types of medium / high volume single and twin stack laminators. Compatible with tilt tray loading systems or large format flat platens. Constructed from structurally reinforced grey silicone, it has a patterned surface.



**C220+ WS** High efficiency lamination pad with increased flexibility, designed for all types of medium / high volume single and twin stack laminators. Compatible with tilt tray assembly systems. Constructed using reinforced white silicone, it has a patterned surface.



**C230 J11** Highly heat conductive lamination pad offering increased productivity, improved handling and durability. Suitable for all medium / high volume laminators. The pad has a woven construction incorporating reinforced silicone and copper filaments.



**MT1** Specifically developed for use with rotary lamination belt line production, this pad features high temperature resistance and fast heat transfer. Constructed from grey silicone with glass fibre reinforcement.

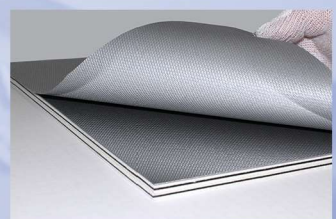

## Suitability Table

Product	Loyalty Cards	Financial Cards	ID Cards	RFID Prelams
C200	✓	✓	x	✓
C220	✓	✓	✓	✓
C220+WS	✓	✓	•	✓
C230 J9/J11/J13	•	•	✓	✓

✓ - Recommended    • - Suitable    x - Not Advised

## Specifications

Product	Thickness (mm) New/In Use*	Max. Temp °C		Typical Cycle (Mins.)	Typical Durability (Cycles)
		Cont.	Peak		
C200	4.6/4.0	180	200	18-25	2000-4000
C220	2.0	210	220	15-22	5000-7000
C220+WS	3.5	180	220	15-22	5000-7000
C230 J9/J11/J13	2.5	210	230	15-20	10000-12000
MT1	0.65	210	220	0.5	10000-50000

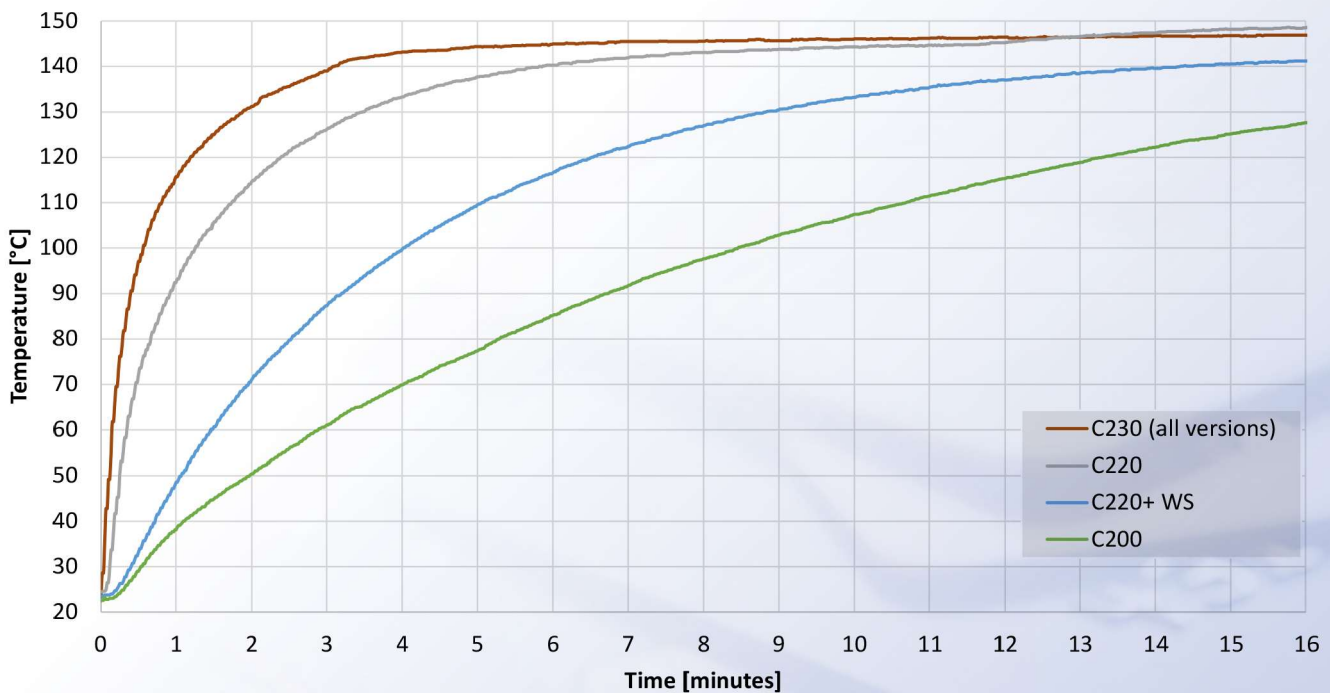

# LAMINATION PLATES

Cardel® lamination plates are precision manufactured to deliver consistent performance and flawless card finishes. They ensure uniform pressure and heat distribution, making them ideal for producing high-quality financial cards, ID cards and other general-purpose cards.



# LAMINATION PLATES

Cardel® produce industry leading standard and bespoke plates in a variety of surface finishes such as gloss, silk and matt, plus a range of technical high security features. Our plates can be supplied in hardened formats or with anti-stick coatings. These extend life and offer our customers the ability to reduce cycle times and increase the quantity of cards produced per cycle without loss of yield.

- Surface finishes suitable for dye sublimation printing, magnetic stripe encoding, GSM cards and all types of smart cards including contactless and combi cards.
- In-house lamination trials are conducted on an ongoing basis to ensure only the highest possible lamination quality is achieved.
- Plates are delivered with self-adhesive low tack film or foam interleave sheets between each plate to protect them during transit.



Finish	Ra [µm] (indicative)	Gloss [GU @20°]	Magstripe encoding	Hologram / Hot foil stamping	Thermal print (direct)	Thermal print (re-transfer)	Drop-on-Demand / Inkjet	Spot UV varnish	RFID prelams	
GLOSS	UG1	(0.02–0.04)	900-1000	✓	✓	✓	✓	• *	✓	✗
	UG2	(0.04–0.06)	600-800	✓	✓	✓	✓	• *	✓	✗
SILK	ISO	0.2–0.4	-	✓	✓	✓	✗	✓	✓	•
	USDS	0.3–0.5	-	• ^	✓	•	✗	✓	✓	•
	US	0.4–0.6	-	• ^	•	•	✗	✓	✓	•
MATT	RM	0.7–0.9	-	✗	✗	✗	✗	•	✓	✓
	UM	0.9–1.1	-	✗	✗	✗	✗	•	✓	✓
	UR	2.5–3.5	-	✗	✗	✗	✗	•	•	✓

✓ - recommended      • - suitable      ✗ - not recommended

^ - Mastercard CQM permits magstripe Ra up to 0.7um, subject to additional checks

\* - Corona or plasma treatment recommended for maximum ink adhesion

## SPECIAL FEATURES (ON REQUEST):

- Matt borders and/or centre stripe to minimise card distortion during lamination (gloss plates only).
- Directional finishes, i.e. brushed finish, polished finish.
- Plates with graphic design and registration pins.
- Custom design plates featuring bespoke images for direct transfer onto card substrate.



## CARDEL-TH LAMINATION PLATES

Cardel® through-hardened plates are 3x harder than standard plates typically used in card manufacturing. They are available in UG1, UG2 and ISO finishes, with thicknesses of 0.6mm and 0.8mm. The increased hardness provides extra durability which extends the plate lifetime and reduces waste caused by damaged plates. This is achieved by effectively preventing dents (caused by RFID inlays, etc.) and significantly reducing scratches that occur in the production environment.

# LAMINATION CASSETTES



Cardel® lamination cassettes are built for efficiency and reliability in card production and are supplied with the top plate as standard. Designed to withstand high temperatures and pressure, they ensure accurate alignment and flawless lamination results. Ideal for the production of financial cards, ID's and other general-use cards.

Card manufacturers who are experiencing high levels of rejected cards due to lamination flaws often do not realise that distorted lamination cassettes can be the root cause of such issues.

# HI BOND ADHESIVES

Cardel Hi Bond<sup>®</sup> is a unique range of high performance heat activated adhesives specifically developed to meet the demands of smart card manufacturing. The range includes adhesives for micromodule embedding as well as specialist films used in the production of metal cards.

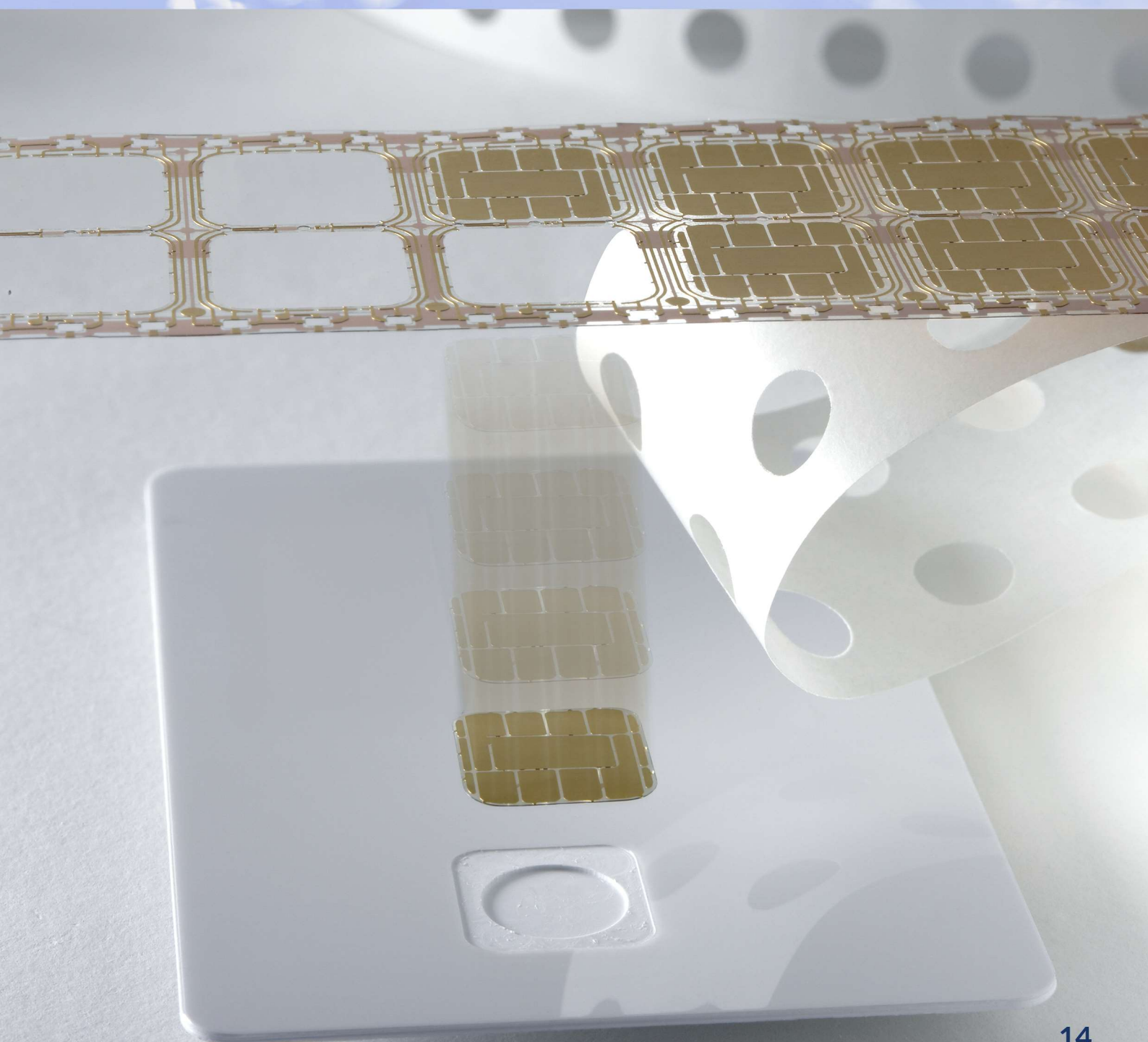

# HI BOND ADHESIVES

Cardel Hi Bond<sup>®</sup> is a unique range of high-performance heat activated adhesives specifically developed to meet the demands of smart card manufacturing. The range includes adhesives for micromodule embedding as well as specialist films used in the production of metal cards.

In recent years, the shelf life of cards has been increasing significantly for commercial and ecological reasons. To boost their durability, polyester and polycarbonate have increasingly been used alongside traditional materials like PVC and ABS. These developments place new demands on the adhesives used to bond the chip.

Cardel<sup>®</sup> has adapted its existing Hi Bond range to reflect these changes and developed adhesives that ensure an exceptional bond between the micromodules and the card. They can withstand mechanical stress and the impact of external factors for several years and are widely used for microprocessor GSM SIM and bank card applications. Cardel Hi Bond<sup>®</sup> adhesives have become the preferred choice of leading chip card manufacturers worldwide.



## CARDEL HI BOND<sup>®</sup> GENERAL FEATURES

- Optimum bond strength. Compliant with Visa/MasterCard/CUP/Verve.
- Fast bonding, enabling high throughput.
- Fabricated as a translucent film to minimise shadowing on the back of the cards.
- High resistance to plasticiser migration.
- Long shelf life.
- Can be stored at room temperature without the need for refrigeration.
- Fully compatible with all major micro-module embedding machines.
- Bespoke variants for specific applications (GSM, metal cards, composite cards).

## CARDEL HI BOND® CLASSIC RANGE

<b>HB3</b>	The world's most used chip embedding adhesive for banking cards (used in approximately 1 in 3 cards globally).
<b>HB2</b>	Primarily used for the embedding of SIM cards (GSM) in the telecoms industry.
<b>HB70-1</b>	For use with FR4 and FCOS™ modules in PVC, ABS, PETG and PC cards.
<b>HB70-B ('Black')</b>	Specialist version of Hi Bond® 70-1 with laser protective properties for the embedding of SIM cards (GSM). It protects against laser burn-through damage in laser personalisation, thus avoiding the yield loss and inconvenience caused by this issue.
<b>HBV</b>	Versions of all the Classic Range products utilising stronger release liner material.

### Suitability Table

Card Material	HB3	HB2	HB70-1	HB70-B
PVC	✓	✓	✓	✓
ABS	✓	✓	✓	✓
PETG	✓	x	x	x
PC	x	x	✓	✓
SIM	x	✓	x	✓

✓ Exceeds ISO and internationally recognised standards for bonding strength, mechanical and environmental performance.

x Not advised

### Specifications

	HB3	HB2	HB70-1	HB70-B
Tape Lamination	110 - 130°C			
Chip Embedding	180 - 210°C			
Adhesive Thickness	36±5 µm *	36±5 µm	40±5 µm	40 ±5 µm
Standard Widths (*)	29mm or 29.5mm			
Standard Lengths (*)	200m or 300m			
Liner Material	89±5 gsm (siliconised paper)			
Core Inside Diameter	3" (76.2mm)			
Storage	2 years at 5°C to 30°C, 20 to 60% RH, with protection from the elements and sunlight			

(\*) Other sizes available on request

## CARDEL HI BOND® 2 ECO ADHESIVE

<b>HB2-E</b>	Bio-based thermoplastic hot melt adhesive, with environmentally friendly 50% bio-based carbon content derived from castor oil
--------------	---

An ecologically improved version of our classic Hi Bond 2 chip adhesive, it is identical in its specifications and performance to the original. Designed for chip embedding into PVC cards and suitable for bonding a wide range of materials, including some ABS blends. Supplied as a film on siliconised paper release liner in reel format.



## CARDEL HI BOND® METAL CARD ADHESIVES

<b>HB-M</b>	A high-performance hotmelt adhesive designed for metal-to-metal bonding.
<b>HB-MPV</b>	A high-performance multi-layer hotmelt adhesive film designed for bonding various plastic materials (PVC, PETG, fibre reinforced epoxies, etc.) to metals (aluminium, stainless steel).

The film is supplied in reel format and without release liner.

### Specifications

	<b>HB-M</b>	<b>HB-MPV</b>
Lamination Temperature	140 - 190°C??	
Adhesive Thickness	33±5 µm	50±5 µm
Standard Widths	200mm - 1200mm (up to 1500mm possible)	
Standard Lengths (*)	100m, 200m, 300m or 600m	100m, 250m or 500m
Liner Material	None	
Core Inside Diameter	3" (76.2mm)	
Storage	2 years at 5°C to 30°C, 20 to 60% RH, with protection from the elements and sunlight	

(\*) Other sizes available on request

# CARDEL HI BOND® ACF ADHESIVE

<b>HB-ACF3</b>	A thermoplastic hot melt adhesive based on HB3, with anisotropic electrical conductivity, enabling current flow through the film thickness (z direction) but insulation in-plane (x and y directions). HB-ACF3 is designed for embedding PVC and ABS dual interface cards and provides increased conductivity.
----------------	--

Supplied as a film on siliconised paper release liner in reel format.

## Specifications

	<b>HB-ACF3</b>
Tape Lamination	130-150°C
Chip Embedding	190 - 210°C
Adhesive Thickness	50±5 µm
Standard Widths (*)	29 or 29.5mm
Standard Lengths (*)	100m
Liner Material	89±5 gsm (siliconised paper)
Core Inside Diameter	3" (76.2mm)
Storage	1 year at 5°C to 30°C, 20 to 60% RH, with protection from the elements and sunlight

## Example using ACF

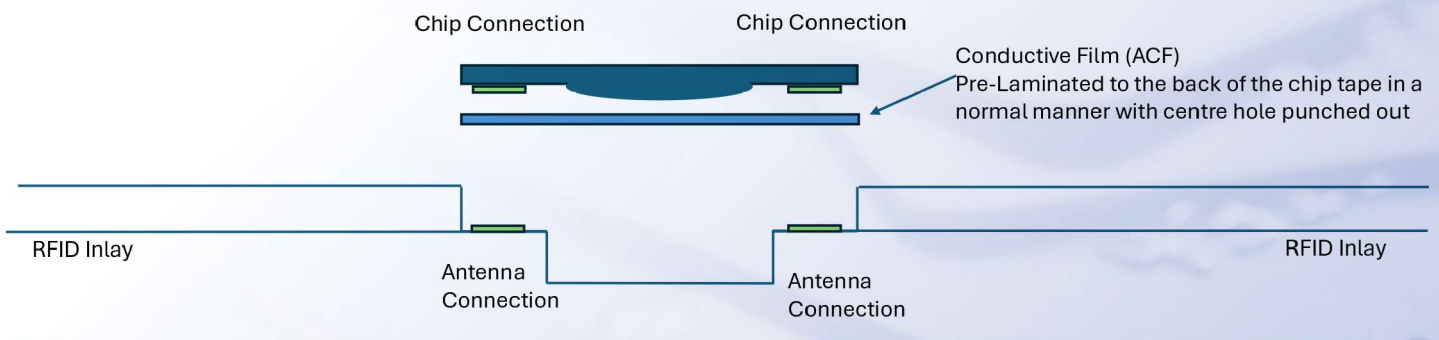

# CARDMATE® CARD AFFIXING LABELS

A range of high-performance card affixing labels for efficient high speed card mailing. Secure and high-speed card mailing is now a common requirement and a range of machines are available to carry out this function. The technology to apply the card to the carrier has moved towards use of labels to provide high speed with secure attachment.

Equally, the variety of card materials and thicknesses has diversified so that the labels are required to work with a range of card types.

- Optimum production / attachment speeds.
- Secure attachment to both card and carrier.
- No damage to card.
- No residue on card.
- Ability to work with different card materials.
- Suitability for all card mailing equipment:
  - Kunnecke
  - CIM
  - Bowe
  - Kern
  - Atlantic Zeisser
  - Fingerlift
  - Matica

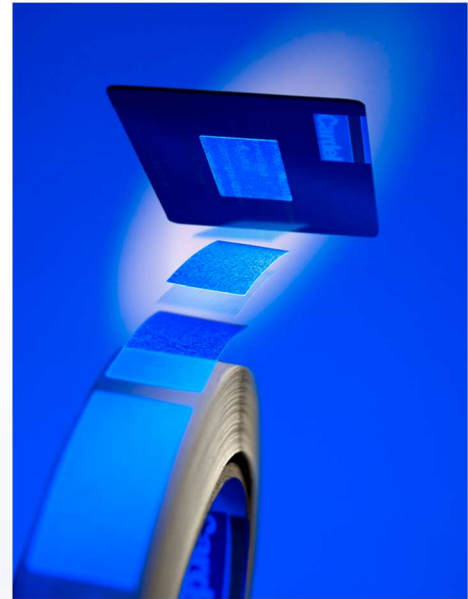

## CLEARZONE LABEL

End customers often complain that the attaching label stays on the card when it is removed from the carrier.

Cardel's research and development team identified that if the attaching label has a clear adhesive zone on the edges of the card side, it ensures that the label remains on the carrier letter. Following extensive laboratory and field testing, Cardel® has now released our new clear zone label for continuous tape products.



- Label stays on the paper, not the card.
- Improved customer experience.
- Easy card removal.
- Continuous adhesive labels.
- Suitable for card attaching equipment e.g. Kunnecke.

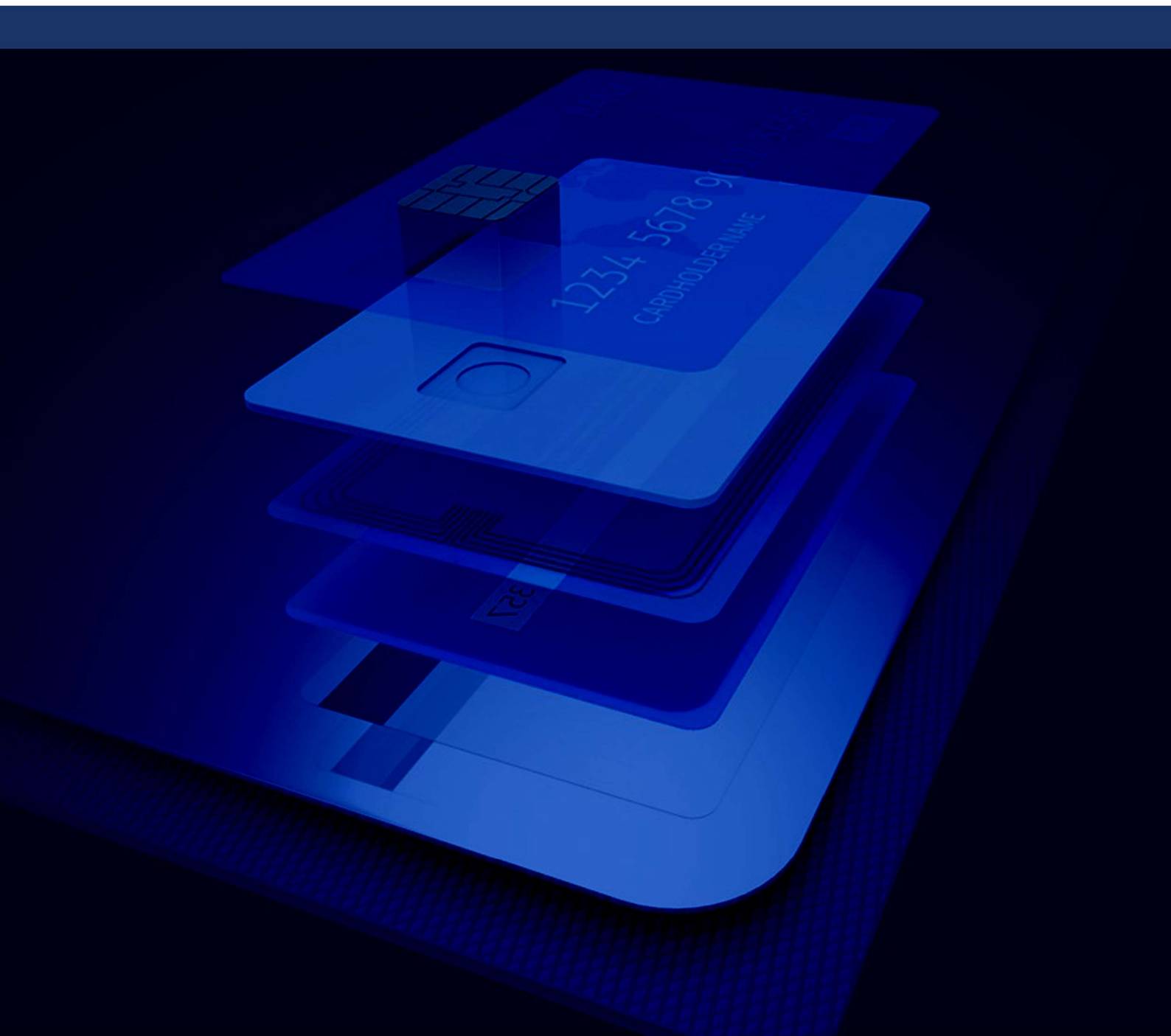

For more information on our product range, or to request a quotation, contact our sales team [sales@cardel.co.uk](mailto:sales@cardel.co.uk)

Tel: +44 (0)1462 491702